

General Description

The AOZ6233 is a 0.35Ω low-voltage Dual Single Pole Double Throw (SPDT) analog switch. The AOZ6233 operates from a single 1.65V to 3.6V supply. It features an ultra-low On Resistance of 0.35Ω at a +2.7V supply and 25°C. The AOZ6233 is designed for break-before-make operation.

Features

- Typical 0.35Ω On Resistance (R_{ON}) for +2.7V supply
- 0.15Ω maximum R_{ON} flatness for +2.7V supply
- 1.6mm x 2.1mm QFN package
- Broad V_{CC} operating range
- Low THD (0.02% typical for 32Ω load)
- High current handling capability (350mA continuous current under 3.3V supply)

Applications

- Cell phone
- PDA
- Portable media player



Typical Application

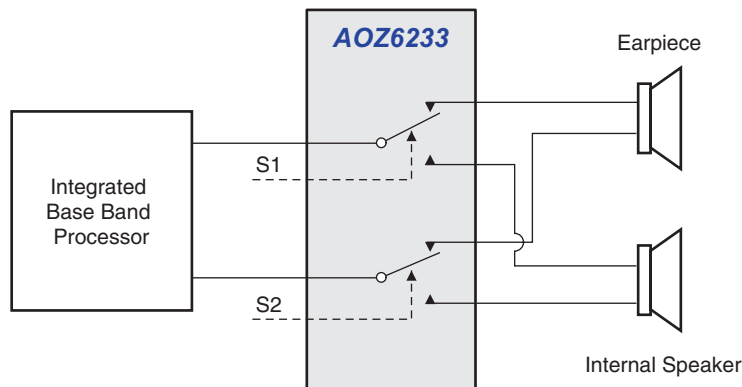

Pin Configuration

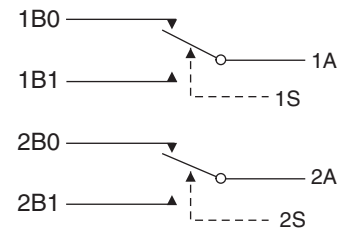

Ordering Information

Part Number	Ambient Temperature Range	Package	Environmental
AOZ6233QI	-40°C to +85°C	QFN-10	RoHS Compliant Green Product



AOS Green Products use reduced levels of Halogens, and are also RoHS compliant. Please visit www.aosmd.com/web/quality/rohs_compliant.jsp for additional information.

Pin Configuration

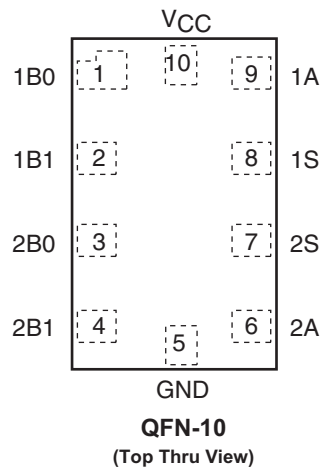

Pin Description

Pin Name	Function
1A, 2A, 1B0, 1B1, 2B0, 2B1	Data Ports
1S, 2S	Control Input

Truth Table

Logic Input	Function
0	B0 Connected to A
1	B1 Connected to A

Absolute Maximum Ratings

Exceeding the Absolute Maximum ratings may damage the device.

Symbol	Parameter	Rating
V_{CC}	Supply Voltage	-0.5V to +5.5V
V_S	Switch Voltage ⁽¹⁾	-0.5 to $V_{CC} + 0.5V$
V_{IN}	Input Voltage ⁽¹⁾	-0.5 to V_{CC}
I_{IK}	Minimum Input Diode Current ⁽²⁾	-50mA
I_{SW}	Switch Current	350mA
I_{SWPEAK}	Peak Switch Current (Pulsed at 1ms duration, <10% Duty Cycle)	500mA
T_{STG}	Storage Temperature Range	-65°C to +150°C
T_J	Maximum Junction Temperature	+150°C
T_L	Lead Temperature (Soldering, 10 seconds)	+260°C
ESD	Human Body Model	8000V
	Charged Device Model	1000V

Recommend Operating Ratings

The device is not guaranteed to operate beyond the Maximum Operating Ratings.

Symbol	Parameter	Rating
V_{CC}	Supply Voltage	1.65V to +3.6V
V_{IN}	Control Input Voltage ⁽³⁾	0V to V_{CC}
V_{SW}	Switch Input Voltage	0V to V_{CC}
T_A	Operating Temperature	-40°C to +85°C

Notes:

1. The input and output negative voltage ratings may be exceeded if the input and output diode current ratings are observed.
2. Negative current should not exceed minimum negative value.
3. Unused inputs must be held HIGH or LOW. They may not float.

DC Electrical Characteristics

All typical values are at 25°C unless otherwise specified.

Symbol	Parameter	Conditions	V _{CC} (V)	Min.	Typ.	Max.	Units
V _{IH}	Input Voltage HIGH		2.7 to 3.6	2.0			V
			2.3 to 2.7	1.7			
			1.65 to 1.95	0.65 x V _{CC}			
V _{IL}	Input Voltage LOW		2.7 to 3.6			0.8	V
			2.3 to 2.7			0.7	
			1.65 to 1.95			0.35 x V _{CC}	
I _{IN}	Control Input Leakage	V _{IN} = 0V to V _{CC}	1.65 to 3.6	-0.5		0.5	μA
I _{NO(OFF)} , I _{NC(OFF)}	Off-Leakage Current of Port nB ₀ and nB ₁	nA = 0.3V, 3.3V, nB0 or nB1 = 0.3V, 3.3V or floating	3.6	-50		50	nA
		nA = 0.3V, 2.4V, nB0 or nB1 = 0.3V, 2.4V or floating	2.7	-50		50	
		nA = 0.3V, 1.65V, nB0 or nB1 = 0.3V, 1.65V or floating	1.95	-50		50	
I _{A(ON)}	On Leakage Current of Port 1A and 2A	nA = 0.3V, 3.3V, nB0 or nB1 = 0.3V, 3.3V or floating	3.6	-50		50	nA
		nA = 0.3V, 2.4V, nB0 or nB1 = 0.3V, 2.4V or floating	2.7	-50		50	
		nA = 0.3V, 1.65V, nB0 or nB1 = 0.3V, 1.65V or floating	1.95	-50		50	
R _{ON}	Switch On Resistance ⁽⁴⁾ See Figure 1	I _{OUT} = 100mA, nB0 or nB1 = 0V, 0.7V, 2.0V, 2.7V	2.7		0.35	0.60	Ω
		I _{OUT} = 100mA, nB0 or nB1 = 0V, 0.7V, 1.6V, 2.3V	2.3		0.40	0.70	
		I _{OUT} = 100mA, nB0 or nB1 = 0.8V	1.65		1.0	3.0	
ΔR _{ON}	On Resistance Matching Between Channels ⁽⁵⁾	I _{OUT} = 100mA, nB0 or nB1 = 0.7V	2.7		0.040	0.075	Ω
			2.3		0.040	0.080	
			1.65		0.1		
R _{FLAT(ON)}	On Resistance Flatness ⁽⁶⁾	I _{OUT} = 100mA, nB0 or nB1 = 0V to V _{CC}	2.7			0.15	Ω
			2.3			0.3	
			1.65		1.6		
I _{CC}	Quiescent Supply Current	V _{IN} = 0V or V _{CC} , I _{OUT} = 0A	3.6	-500		500	nA
I _{CCT}	Increase in I _{CC} per Input	V _{IN} = 1.8V	3.6		75		μA
		V _{IN} = 2.6V			5		

Notes:

- On resistance is determined by the voltage drop between A and B pins at the indicated current through the switch.
- ΔR_{ON} = R_{ONmax} – R_{ONmin} measured at identical V_{CC}, temperature, and voltage.
- Flatness is defined as the difference between the maximum and minimum value of R_{ON} over the specified range of conditions.

AC Electrical Characteristics

All typical values are at 25°C unless otherwise specified.

Symbol	Parameter	Conditions	V _{CC} (V)	Min.	Typ.	Max.	Units
t _{ON}	Turn-On Time	nB0 or nB1 = 1.5V, R _L = 50Ω, C _L = 35pF	2.7 to 3.6		40.0	50.0	ns
			2.3 to 2.7		50.0	55.0	
			1.65 to 1.95		75.0	85.0	
t _{OFF}	Turn-Off Time	nB0 or nB1 = 1.5V, R _L = 50Ω, C _L = 35pF	2.7 to 3.6		10.0	20.0	ns
			2.3 to 2.7		20.0	25.0	
			1.65 to 1.95		50.0	55.0	
t _{BBM}	Break-Before-Make Time	nB0 or nB1 = 1.5V, R _L = 50Ω, C _L = 35pF	2.7 to 3.6	2.0	17.0		ns
			2.3 to 2.7	2.0	15.0		
			1.65 to 1.95	2.0	12.0		
Q	Charge Injection	C _L = 100pF, V _{GEN} = 0V, R _{GEN} = 0Ω	1.65 to 3.6		9.0		pC
OIRR	Off Isolation	f = 100kHz, R _L = 50Ω, C _L = 5pF (Stray)	1.65 to 3.6		-95		dB
Xtalk	Crosstalk	f = 100kHz, R _L = 50Ω, C _L = 5pF (Stray)	1.65 to 3.6		-95		dB
BW	-3dB Bandwidth	R _L = 50Ω	1.65 to 3.6		45.0		MHz
THD	Total Harmonic Distortion	R _L = 32Ω, V _{IN} = 2V _{pk-pk} , f = 20Hz to 20kHz	2.7 to 3.6		0.024		%
		R _L = 32Ω, V _{IN} = 1.5V _{pk-pk} , f = 20Hz to 20kHz	2.3 to 2.7		0.015		
		R _L = 32Ω, V _{IN} = 1.2V _{pk-pk} , f = 20Hz to 20kHz	1.65 to 1.95		0.35		

Capacitance

Symbol	Parameter	Conditions	V _{CC} (V)	Min.	Typ.	Max.	Units
C _{IN}	Control Pin Input Capacitance	f = 1MHz	0.0		4		pF
C _{OFF}	B Port Off Capacitance	f = 1MHz	3.3		22		pF
C _{ON}	A Port On Capacitance	f = 1MHz	3.3		140		pF

Typical Performance Characteristics

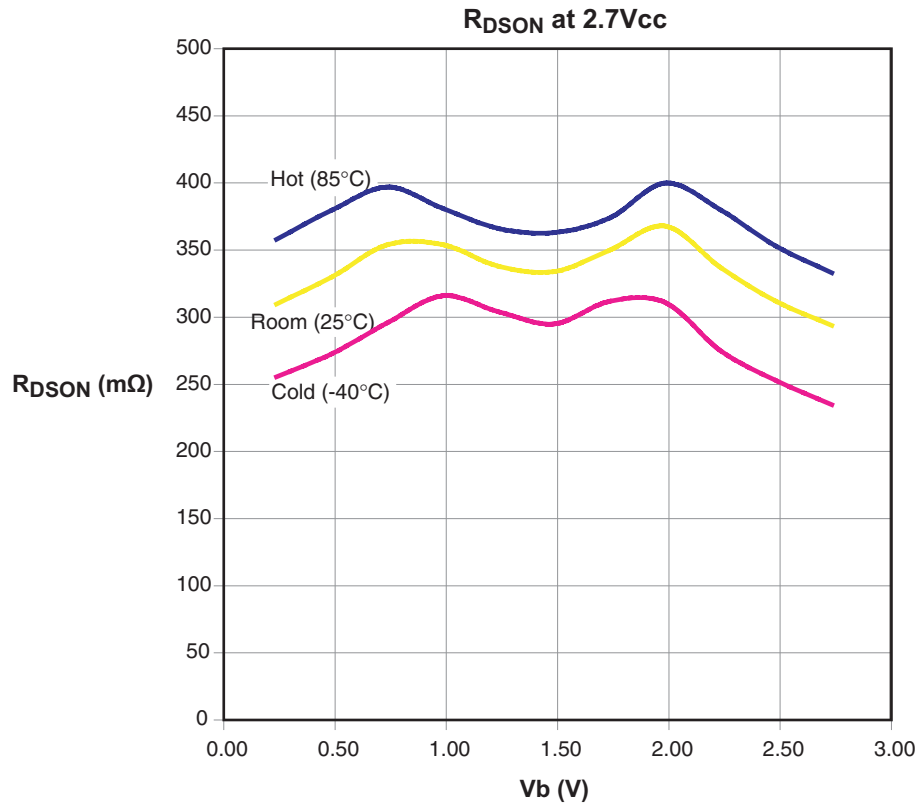

Figure 1. Switch On Resistance

AC Loading and Waveforms

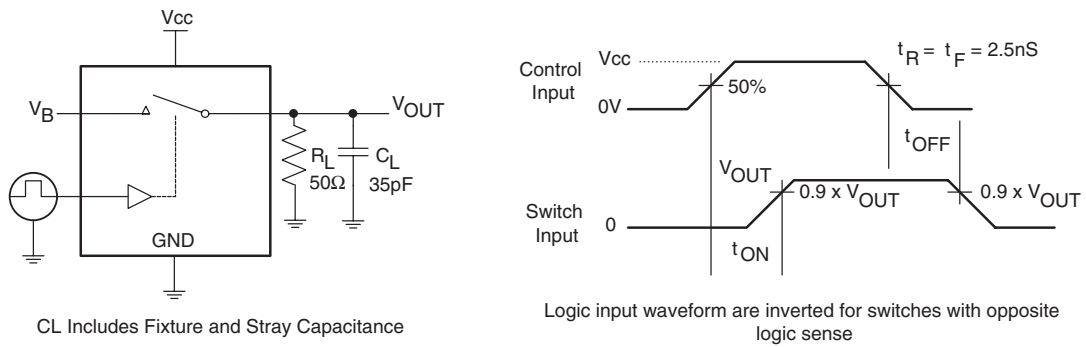

Figure 2. Turn-On/Turn-Off Timing

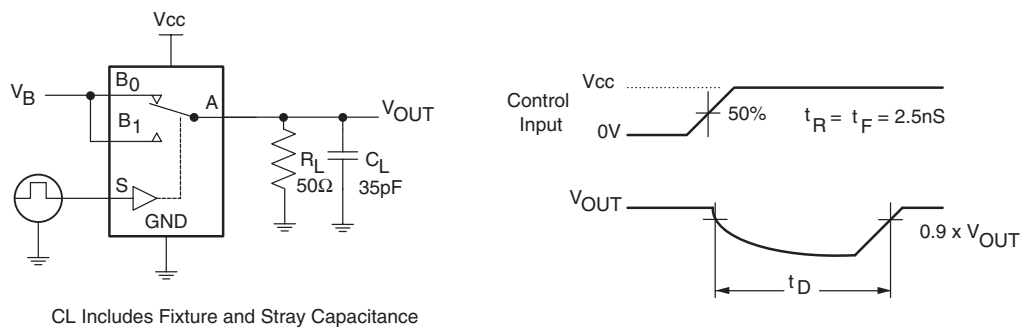

Figure 3. Break-Before-Make Timing

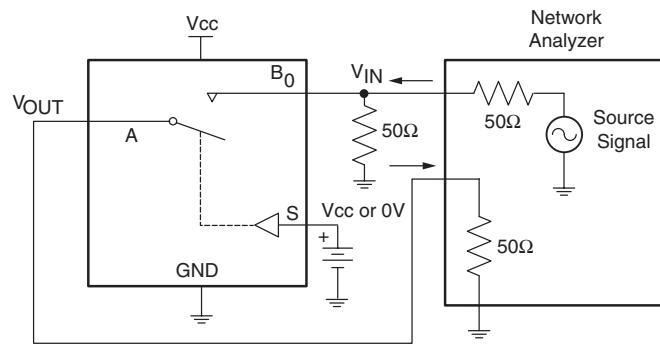

Figure 4. Off Isolation

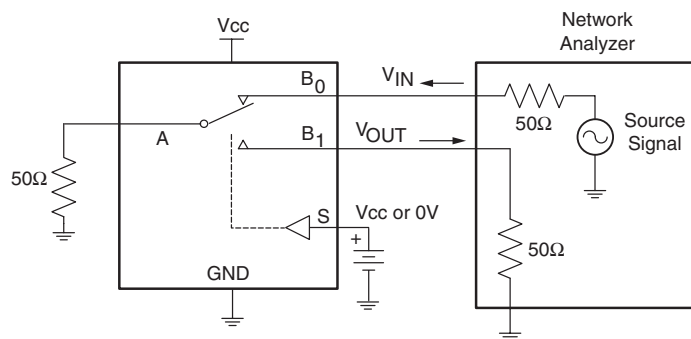

Figure 5. Crosstalk

AC Loading and Waveforms (continued)

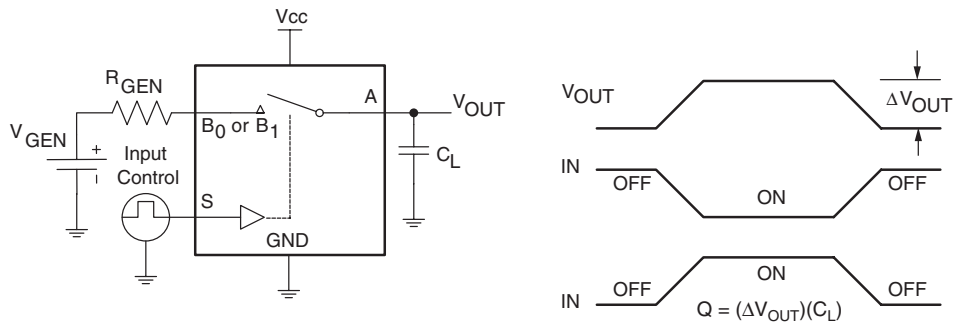

Figure 6. Charge Injection

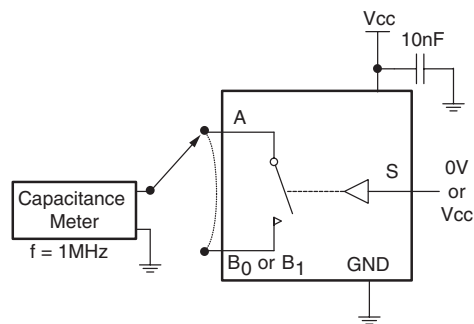

Figure 7. ON/Off Capacitance Measurement

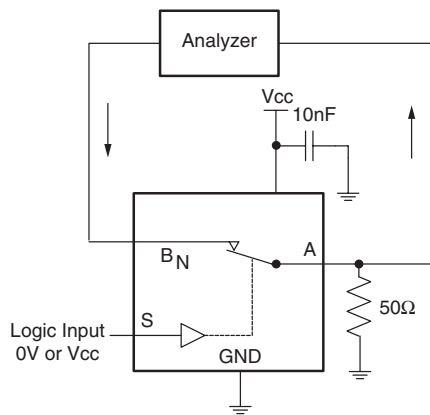

Figure 8. Bandwidth

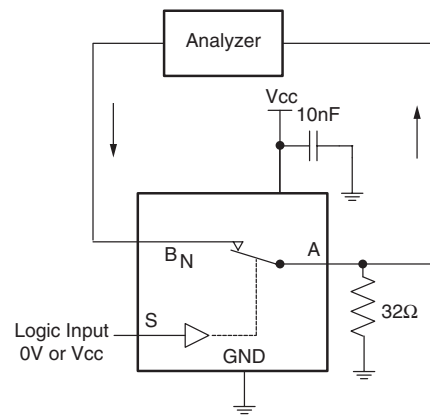
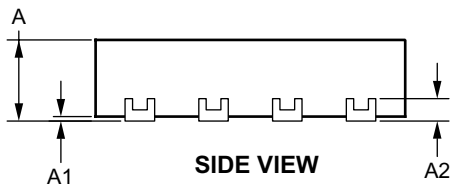
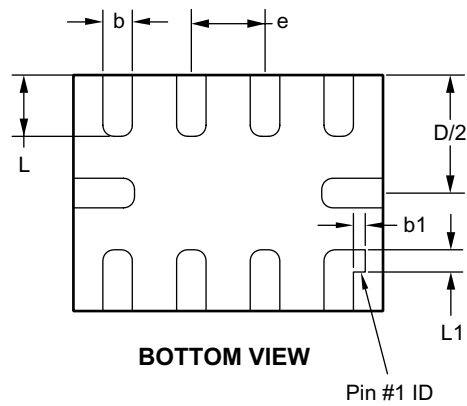
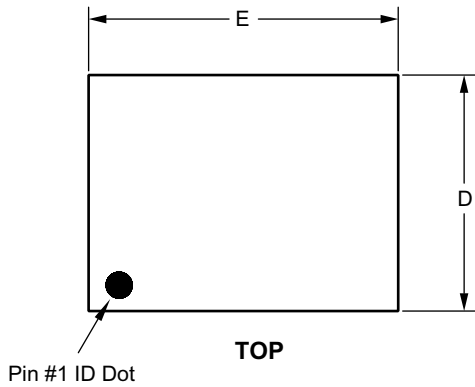

Figure 9. Harmonic Distortion

Package Dimensions, QFN-10



Dimensions in millimeters

Symbols	Min.	Nom.	Max.
A	0.50	0.55	0.60
A1	0.00	—	0.05
A2	0.152 REF.		
b	0.15	0.20	0.25
b1	0.08 REF.		
D	1.55	1.60	1.65
E	2.05	2.10	2.15
e	0.50 BSC		
L	0.365	0.415	0.465
L1	0.15 REF.		

Dimensions in inches

Symbols	Min.	Nom.	Max.
A	0.020	0.022	0.024
A1	0.00	—	0.002
A2	0.006 REF.		
b	0.006	0.008	0.010
b1	0.003 REF.		
D	0.061	0.063	0.065
E	0.081	0.083	0.085
e	0.020 BSC		
L	0.014	0.016	0.018
L1	0.006 REF.		

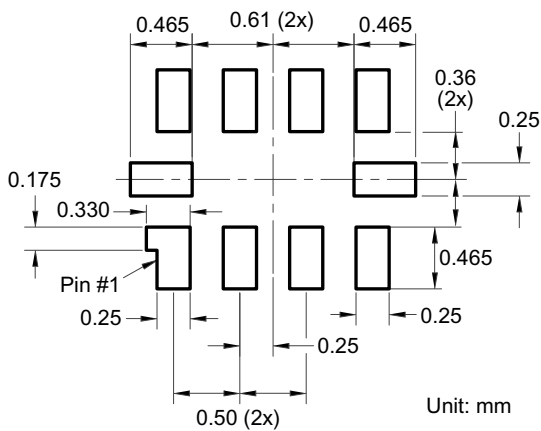

Note:

1. Controlling dimension is millimeter. Converted inch dimensions are not necessarily exact.

Tape and Reel Dimensions, QFN-10

Carrier Tape

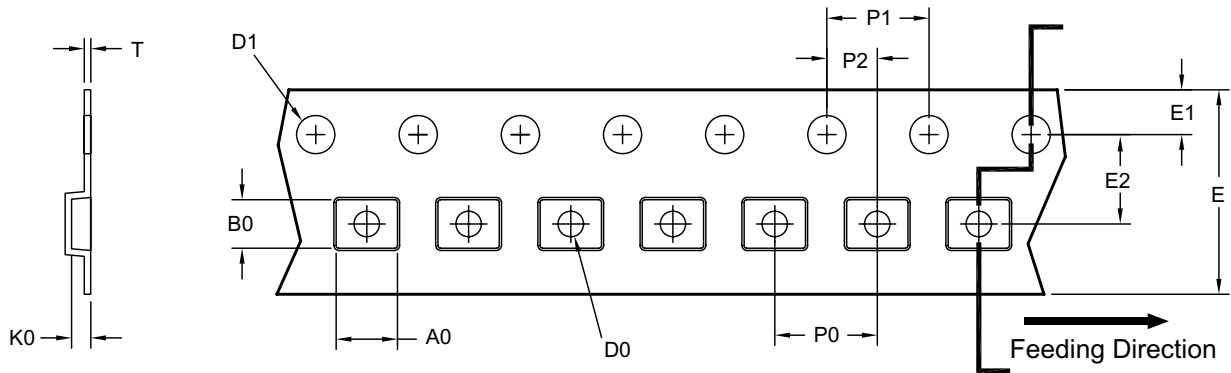

UNIT: mm

Package	A0	B0	K0	D0	D1	E	E1	E2	P0	P1	P2	T
QFN 2.1 x 1.6 (8mm)	0.76 ±0.05	1.21 ±0.05	0.53 ±0.05	0.50 ±0.05	1.5 ±0.10	8.00 +0.30/-0.10	1.75 ±0.10	3.50 ±0.05	4.00 ±0.10	4.00 ±0.10	2.00 ±0.05	0.254 ±0.02

Reel

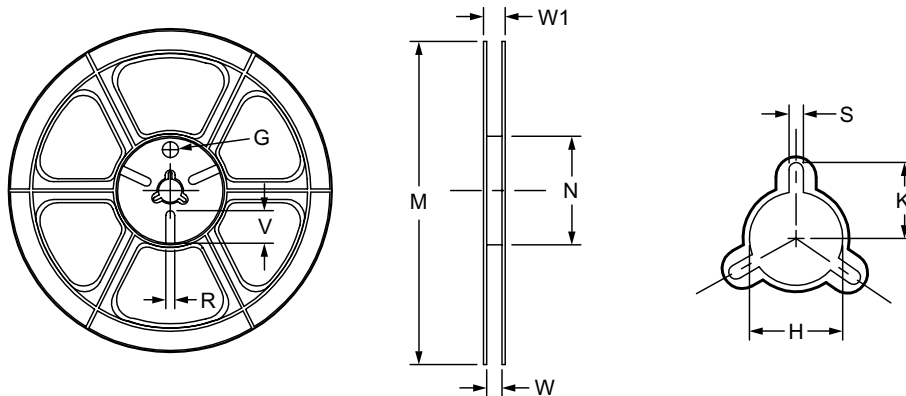

UNIT: mm

Tape Size	Reel Size	M	N	W	W1	H	K	S	G	R	V
8mm	ø178	ø178 ±0.5	ø55 ±1	8.4 +1.5/0	14.4 Max.	ø13.0 ±0.5	10.1 Max.	2.0 ±0.5	N/A	N/A	N/A

Leader/Trailer and Orientation

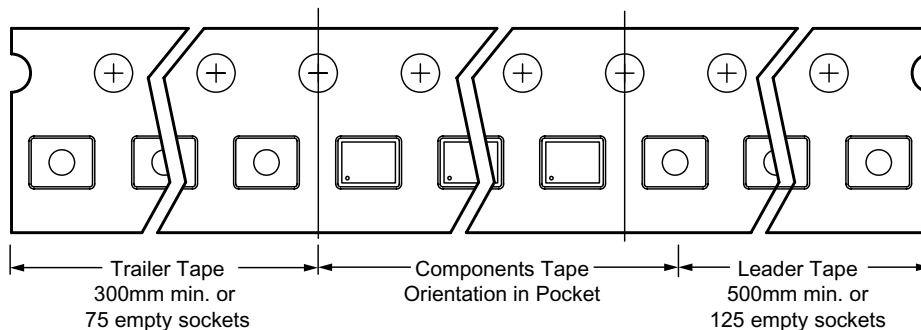

Part Marking

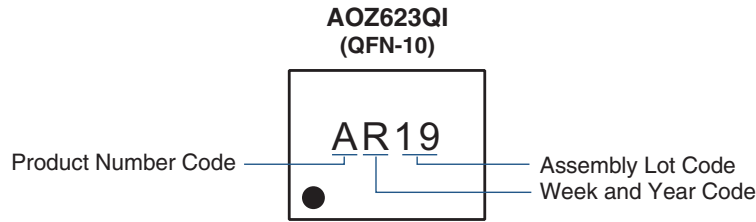

This datasheet contains preliminary data; supplementary data may be published at a later date. Alpha & Omega Semiconductor reserves the right to make changes at any time without notice.

LIFE SUPPORT POLICY

ALPHA & OMEGA SEMICONDUCTOR PRODUCTS ARE NOT AUTHORIZED FOR USE AS CRITICAL COMPONENTS IN LIFE SUPPORT DEVICES OR SYSTEMS.

As used herein:

1. Life support devices or systems are devices or systems which, (a) are intended for surgical implant into the body or (b) support or sustain life, and (c) whose failure to perform when properly used in accordance with instructions for use provided in the labeling, can be reasonably expected to result in a significant injury of the user.
2. A critical component in any component of a life support, device, or system whose failure to perform can be reasonably expected to cause the failure of the life support device or system, or to affect its safety or effectiveness.