

PCB TYPE PHOTOINTERRUPTER

*Features

- Ultra-compact with a 6.0mm width photointerrupter and 3mm width slot.
- PCB surface mounting type.
- High resolution with a 0.5mm width aperture.
- RoHS compliant.

*Dimensions

Note:1:All units are in millimeters unless otherwise indicated.

2:Burrs with a dimension less than 0,25mm, which will not influence product functionality, are acceptable.

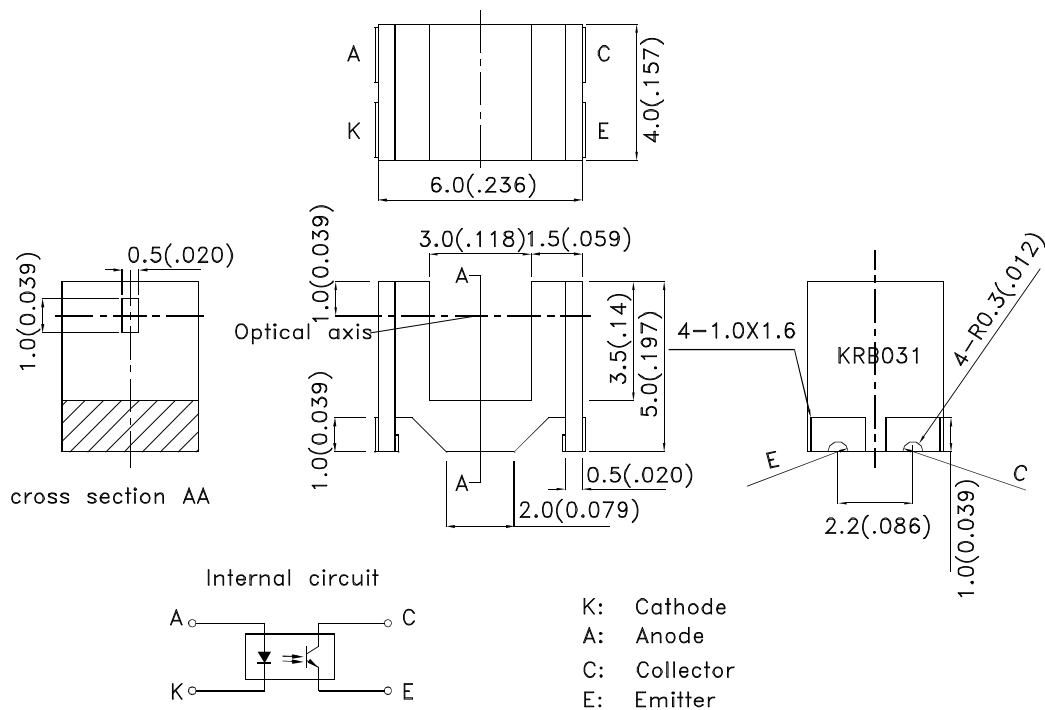

Recommend Soldering Pattern

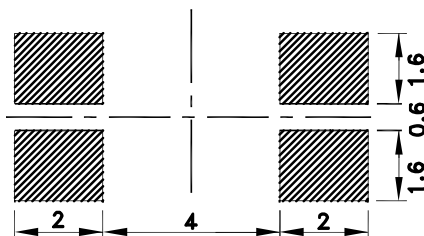

Unless otherwise, the tolerances are ± 0.15 mm.



***Absolute Maximum Ratings (T_a=25°C)**

Parameter		Symbol	Rating	Unit
Input	Forward current[1]	I _F	25	mA
	Reverse voltage	V _R	5	V
	Power dissipation	P _d	35	mW
	Peak Forward Current (Pulse Width ≤100uS, Duty Cycle=1%)	I _{FP}	1	A
Output	Collector-emitter voltage	V _{CEO}	20	V
	Emitter-collector voltage	V _{ECO}	5	V
	Collector current	I _C	20	mA
	Collector power dissipation	P _C	75	mW
Operating temperature		T _{opr}	-40~+85	°C
Storage temperature		T _{stg}	-40~+90	°C
Soldering temperature[2]		T _{sol}	260	°C
Manual soldering[2]		T _{sol}	300	°C

Notes:

- 1.Refer to the temperature ratingchart if the ambient temperature exceeds 25°C.
- 2.Complete soldering within 10 seconds for reflow soldering and within 3 seconds for manual soldering.

***Electrical / Optical Characteristics at T_A=25°C**

Parameter		Symbol	Value			Conditions
			Min.	Typ.	Max.	
Input	Forward voltage	V _F	-	1.1V	1.3V	I _F =5mA
	Reverse current	I _R	-	-	10μA	V _R =5V
	Peak Wavelength	λ _p	-	940nm	-	I _F =20mA
Output	Collector current	I _C	50μA	150μA	500μA	I _F =5mA, V _{CE} =5V
	Collector dark current	I _D	-	-	100nA	V _{CE} =10V, 0LX
	Collector-emitter saturation voltage	V _{CE(sat)}	-	0.1V	0.4V	I _C =50μA, I _F =20mA
	Peak spectral sensitivity wavelength	λ _p	-	920nm	-	-
Rise time		t _r	-	8μsec	-	V _{CC} =5V, R _L =1KΩ I _C =100μA
Fall time		t _f	-	10μsec	-	

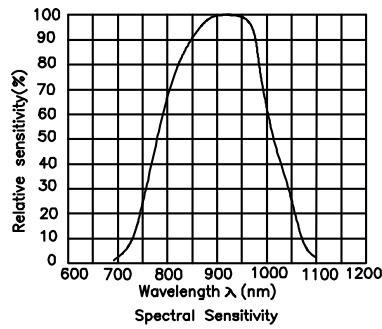

Fig.1 Forward Current vs. Forward Voltage

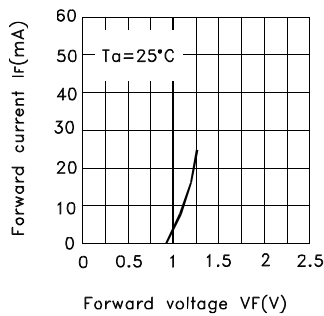

Fig.2 Collector Current vs. Forward Current

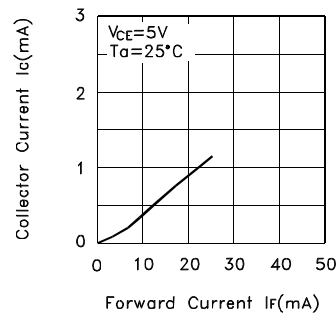

Fig.3 Collector Current vs. Ambient Temperature

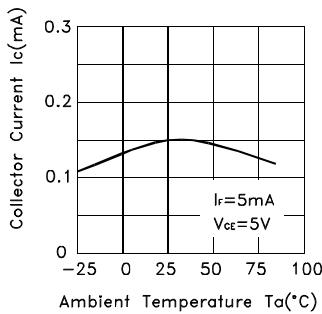

Fig.4 Collector-Emitter Saturation Voltage vs. Ambient Temperature

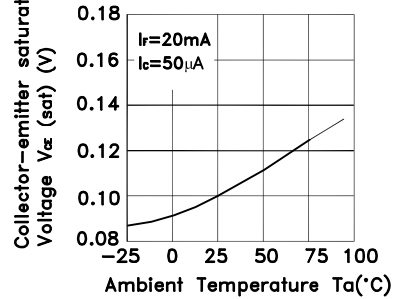

Fig.5 Forward Current vs. Collector Dissipation Temperature Rating

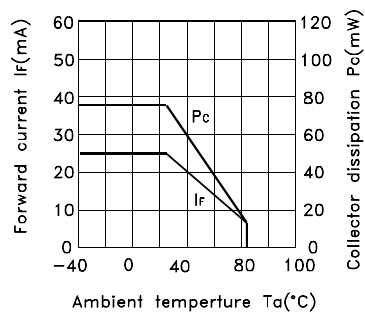

Fig.6 Collector Current vs. Collector-Emitter Voltage

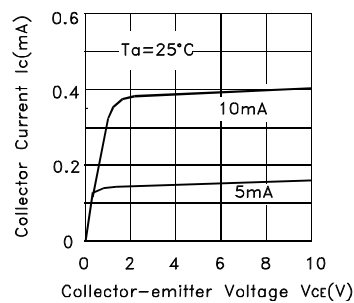

Fig.7 Relative Collector Current vs. Shield Distance(1)

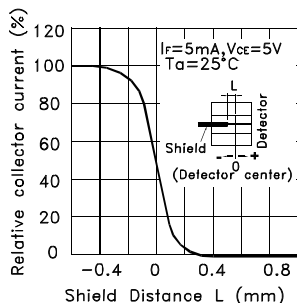

Fig.8 Relative Collector Current vs. Shield Distance(2)

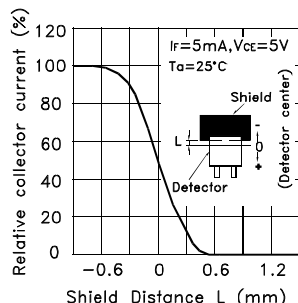
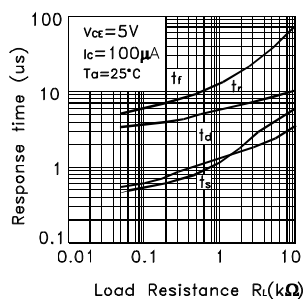
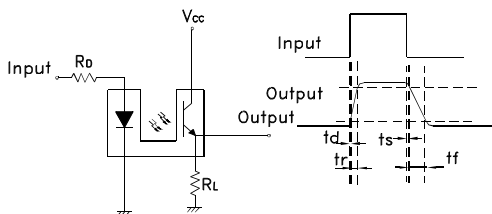

Fig.9 Response Time vs. Load Resistance



Test Circuit for Response Time



Reflow Soldering Profile For Lead-free SMT Process.

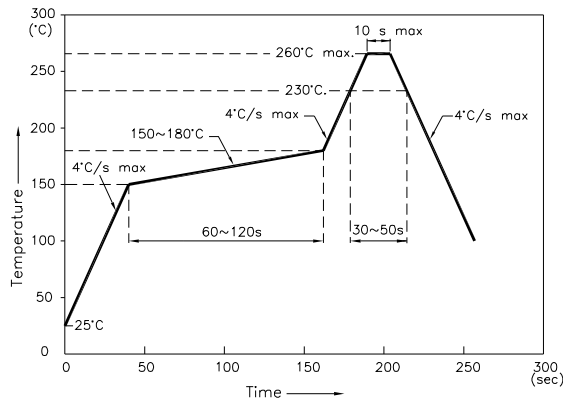

NOTES:

1. We recommend the reflow temperature 245°C(+/-5°C). The maximum soldering temperature should be limited to 260°C.
2. Don't cause stress to the epoxy resin while it is exposed to high temperature.
3. Number of reflow process shall be 2 times or less.

Reel Dimensions (Units: mm)

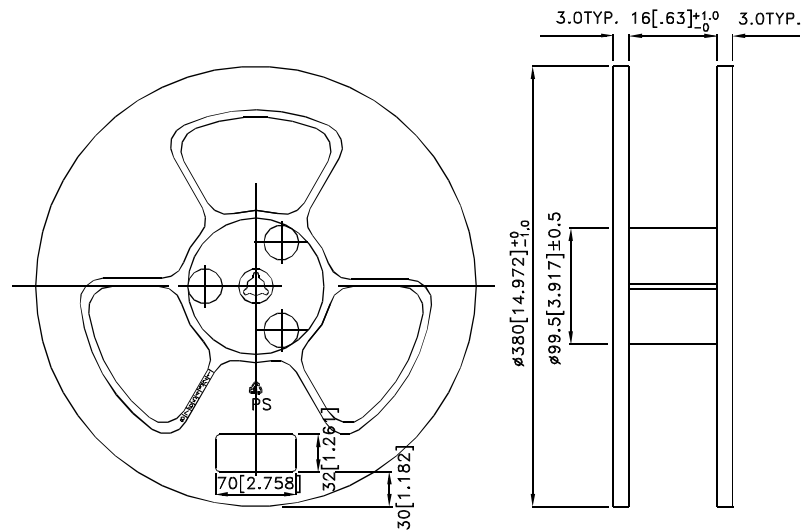

Tape Specifications (Units: mm)

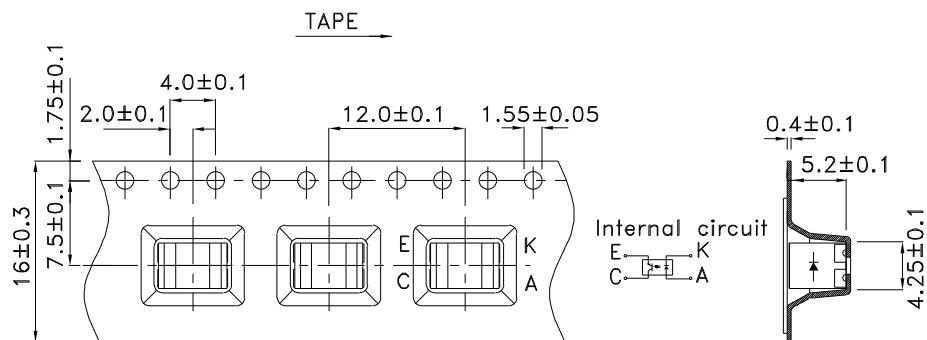

Tape quantity 1000pcs/reel

